

# HPC P系列 | 變量柱塞泵浦

## HL EDG型

### Type HL EDG

負荷感應+壓力比例控制型

P	16	-	HL	3	-	EDG	-	F	-	R	-	(S)	-	01
---	----	---	----	---	---	-----	---	---	---	---	---	-----	---	----

#### \*壓力

1:20-75 bar(P08-P100)

2:25-145 bar(P08-P100)

3:30-215 bar(P08-P100)

4:30-280 bar(P70-P100)

P08/10/13-HL\*-EDG-F-R-TYPE

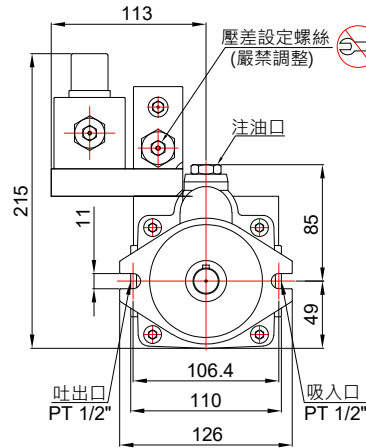
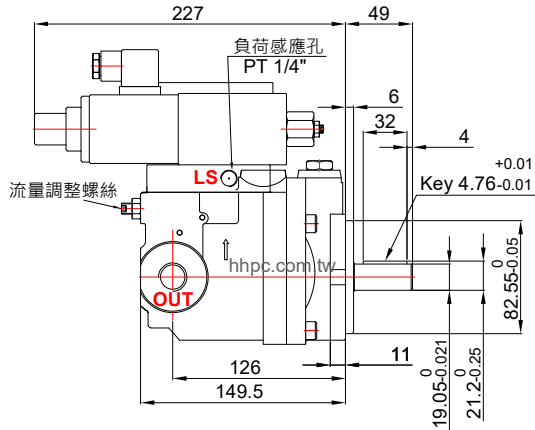

P16/22-HL\*-EDG-F-R-TYPE

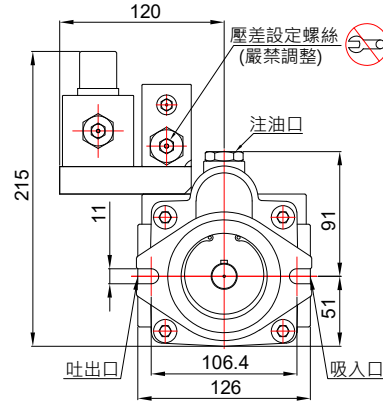
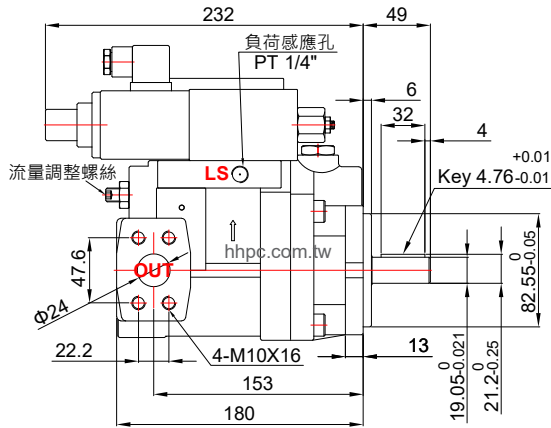

P36/46-HL\*-EDG-F-R-TYPE

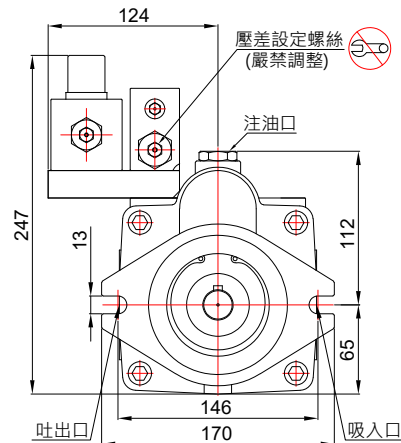
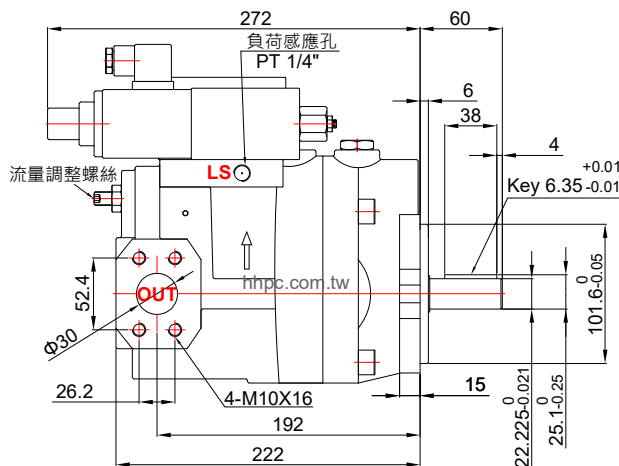

負荷感應+壓力比例控制型

Type HL EDG

P	16	-	HL	3	-	EDG	-	F	-	R	-	(S)	-	01
---	----	---	----	---	---	-----	---	---	---	---	---	-----	---	----

P70-HL\*-EDG-F-R-TYPE

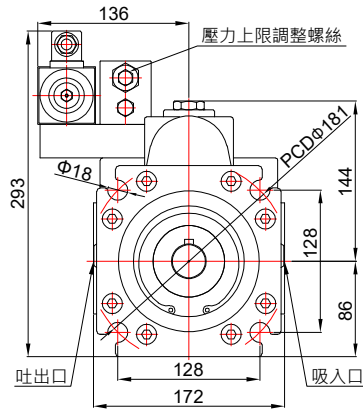
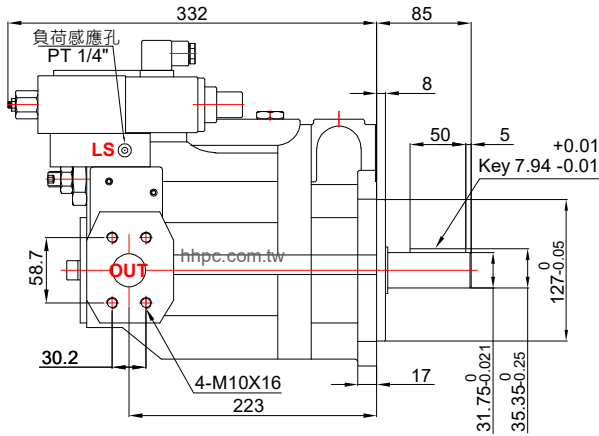
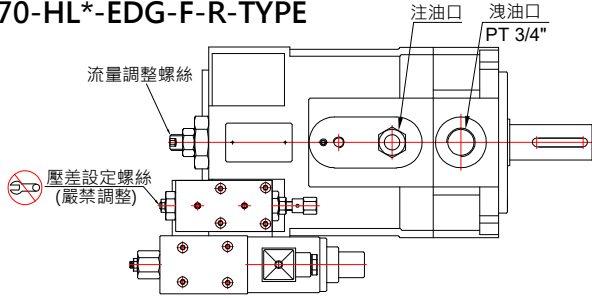

P100-HL\*-EDG-F-R-TYPE

