

Type E 電磁兩段壓力控制型

P	16	-	E	3	-	ED*	-	F	-	R	-	(S)	-	01
---	----	---	---	---	---	-----	---	---	---	---	---	-----	---	----

*壓力(SOL-ON)

- 1:20-75 bar(P08-P100)
- 2:25-145 bar(P08-P100)
- 3:30-215 bar(P08-P100)

P08/10/13-E*-F-R-TYPE

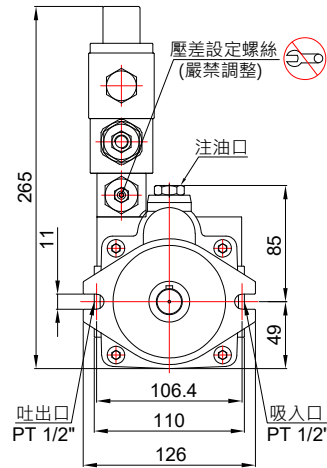
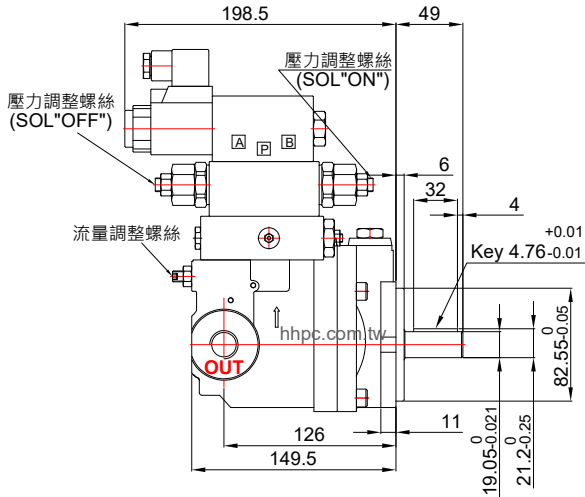

P16/22-E*-F-R-TYPE

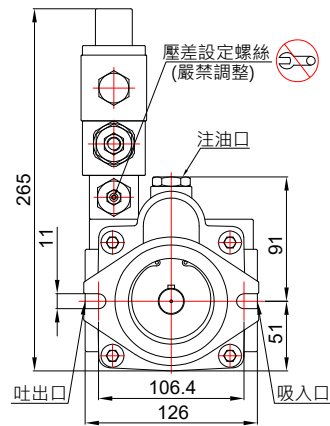
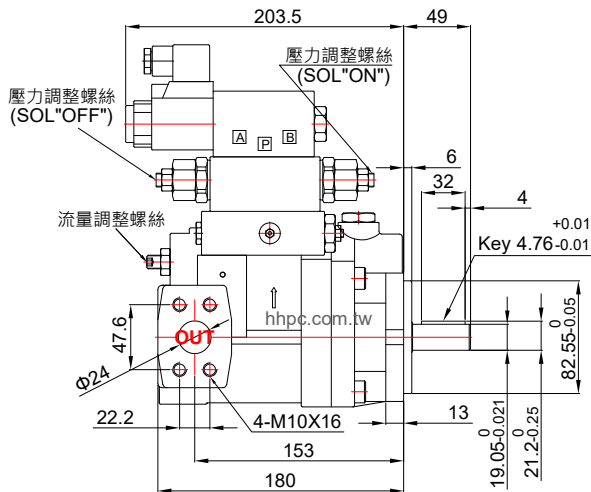

P36/46-E*-F-R-TYPE

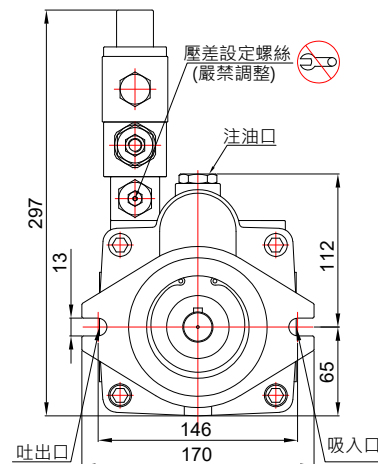
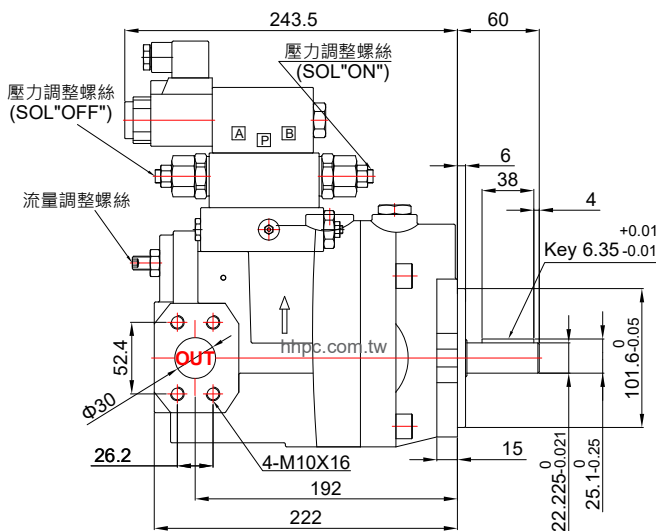

電磁兩段壓力控制型

Type E

P	16	-	E	3	-	ED*	-	F	-	R	-	(S)	-	01
---	----	---	---	---	---	-----	---	---	---	---	---	-----	---	----

P70-E*-F-R-TYPE

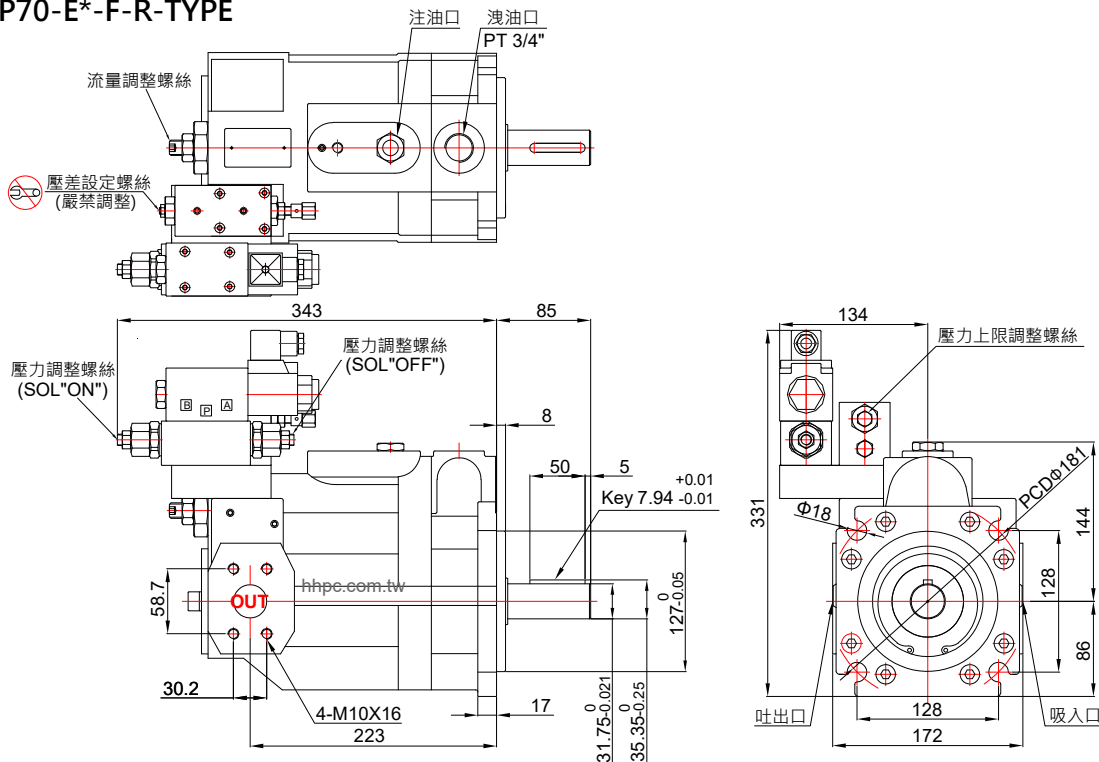

P100-E*-F-R-TYPE

