

Type D 電磁低壓卸載型

P	16	-	D	3	-	ED*	-	F	-	R	-	(S)	-	01
---	----	---	---	---	---	-----	---	---	---	---	---	-----	---	----

P08/10/13-D*-F-R-TYPE

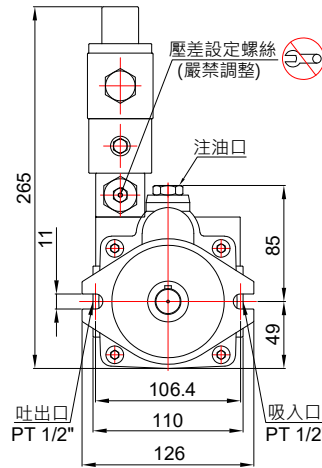
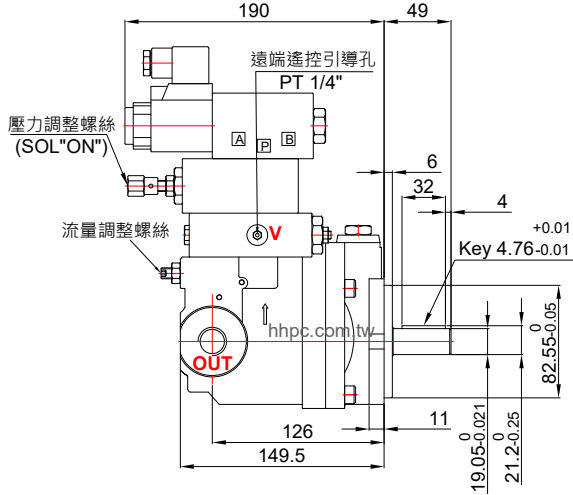

***壓力(SOL-ON)**

- 1:20-75 bar(P08-P100)
- 2:25-145 bar(P08-P100)
- 3:30-215 bar(P08-P100)
- 4:30-280 bar(P70-P100)

P16/22-D*-F-R-TYPE

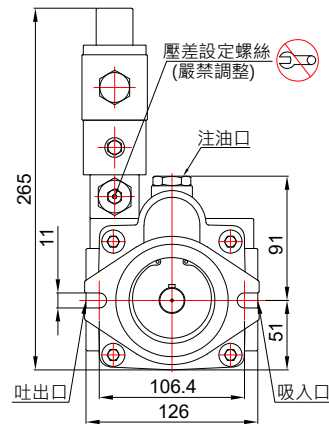
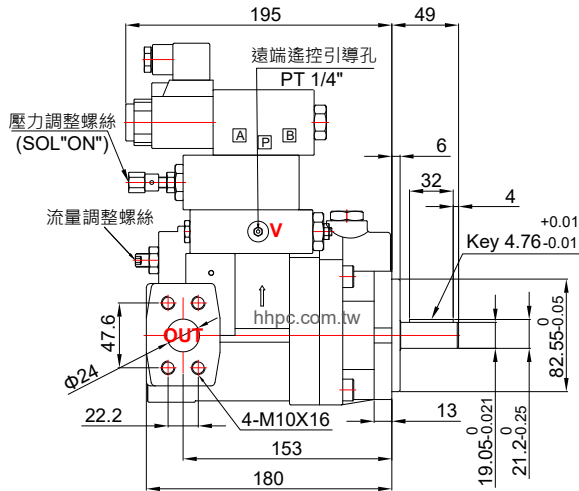

P36/46-D*-F-R-TYPE

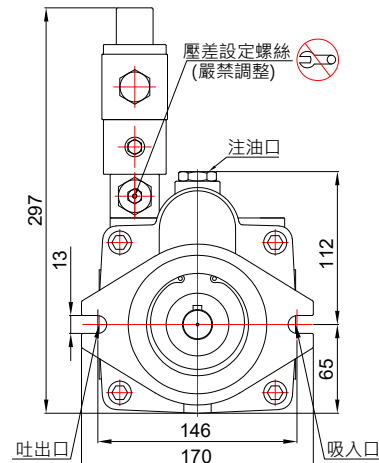
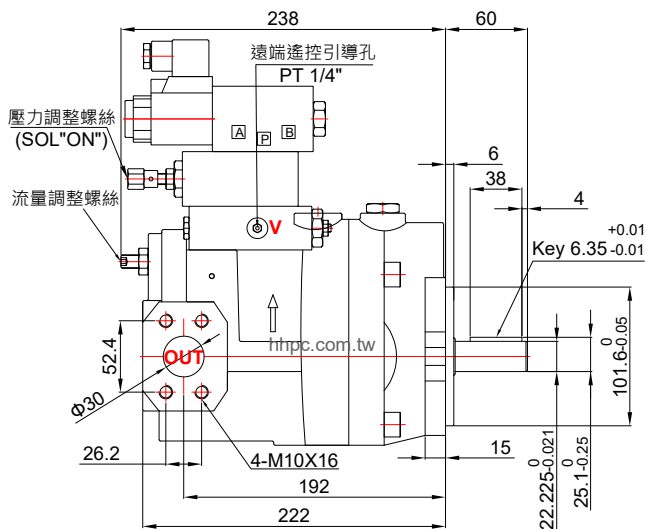

電磁低壓卸載型

Type D

P	16	-	D	3	-	ED*	-	F	-	R	-	(S)	-	01
---	----	---	---	---	---	-----	---	---	---	---	---	-----	---	----

P70-D*-F-R-TYPE

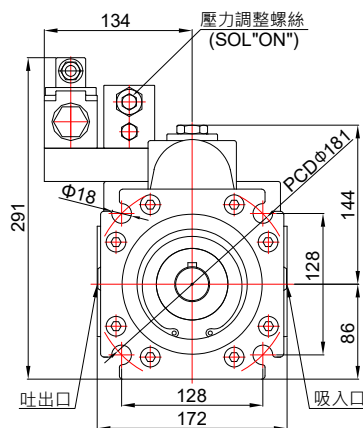
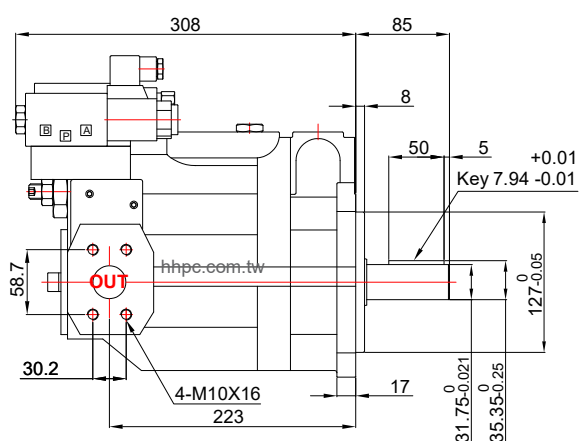
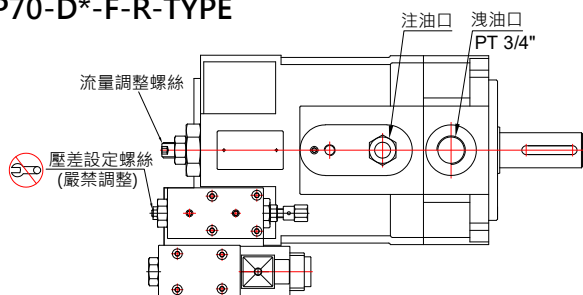

P100-D*-F-R-TYPE

