

遠端遙控附高壓保護型

Type BH

P	16	-	BH	3	-	ED*	-	F	-	R	-	(S)	-	01
---	----	---	----	---	---	-----	---	---	---	---	---	-----	---	----

*壓力

1:20-75 bar(P08-P46)

2:25-145 bar(P08-P46)

3:30-215 bar(P08-P46)

P08/10/13-BH*-F-R-TYPE

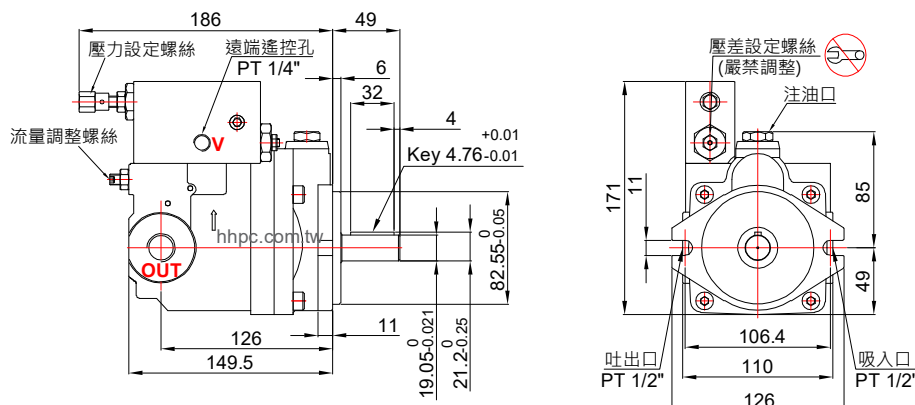

P16/22-BH*-F-R-TYPE

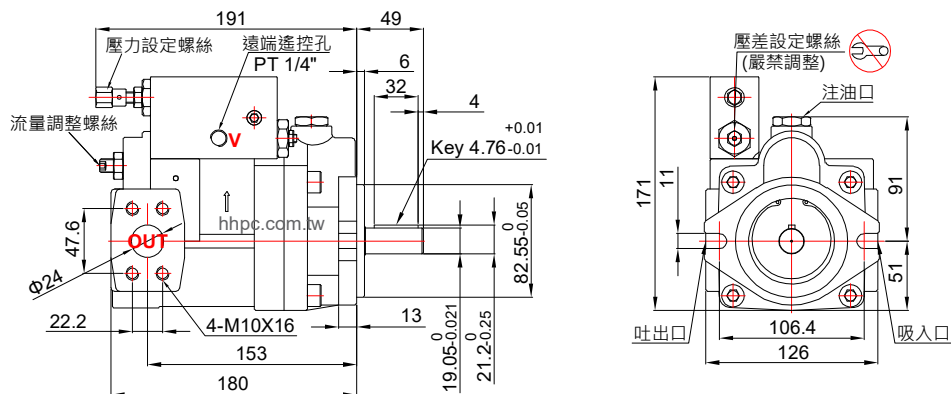

P36/46-BH*-F-R-TYPE

