

Type A 壓力補償型

| | | | | | | | | | | | | | | |
|---|----|---|---|---|---|-----|---|---|---|---|---|-----|---|----|
| P | 16 | - | A | 3 | - | ED* | - | F | - | R | - | (S) | - | 01 |
|---|----|---|---|---|---|-----|---|---|---|---|---|-----|---|----|

*壓力

- 0:15-45 bar(P08-P46)
- 1:20-75 bar(P08-P100)
- 2:25-145 bar(P08-P100)
- 3:30-215 bar(P08-P100)
- 4:30-280 bar(P70-P100)

P08/10/13-A*-F-R-TYPE

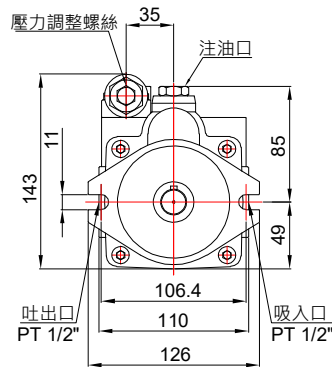
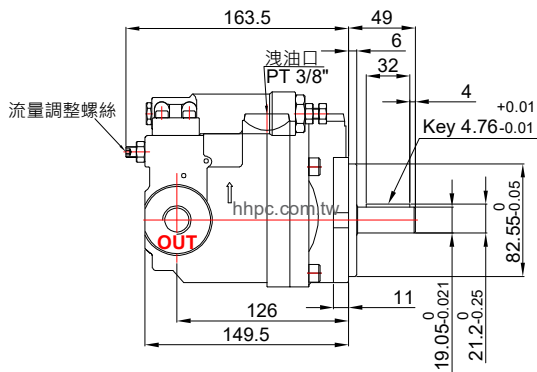

P16/22-A*-F-R-TYPE

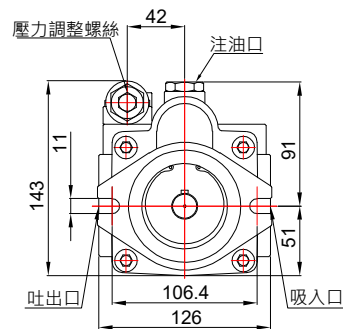
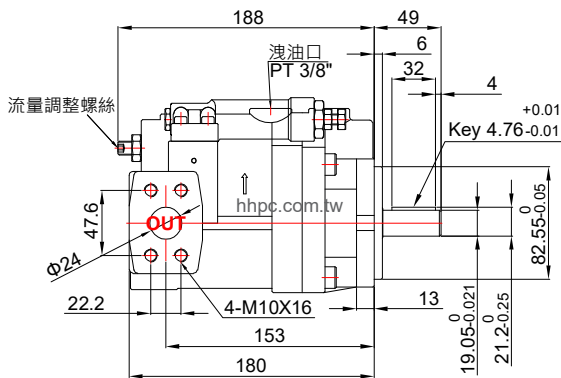

P36/46-A*-F-R-TYPE

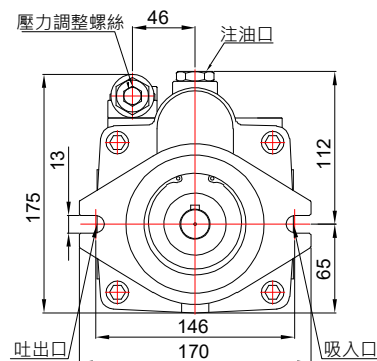
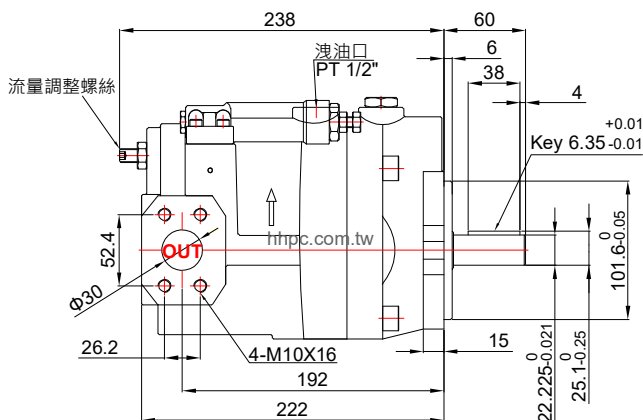

壓力補償型

Type A

| | | | | | | | | | | | | | | |
|---|----|---|---|---|---|-----|---|---|---|---|---|-----|---|----|
| P | 16 | - | A | 3 | - | ED* | - | F | - | R | - | (S) | - | 01 |
|---|----|---|---|---|---|-----|---|---|---|---|---|-----|---|----|

P70-A*-F-R-TYPE

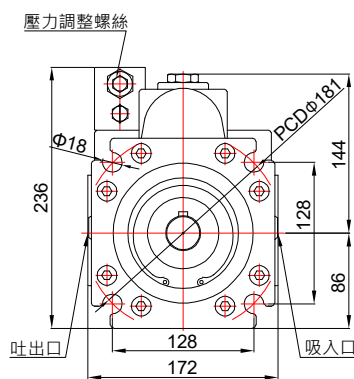
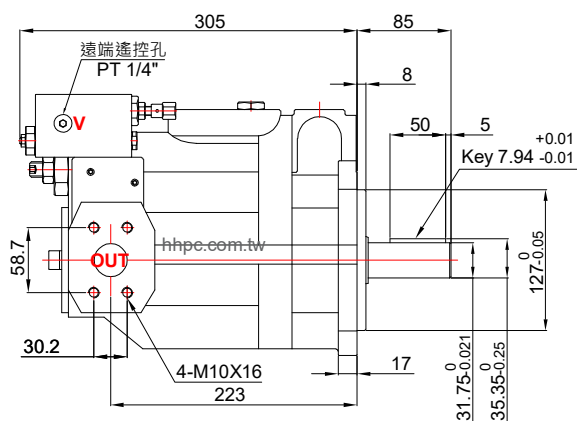
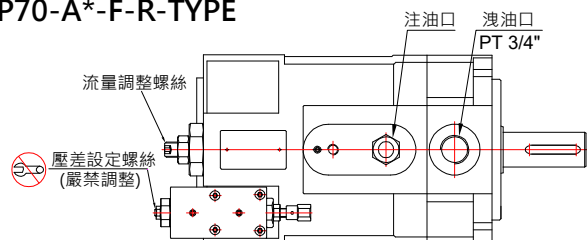

P100-A*-F-R-TYPE

